

ZANUSSI

FREEZER
ZVC 67

INSTRUCTION BOOKLET

CONTENTS

Warnings page	3
Conservation page	4
Installation page	5
Positioning page	5
Rear spacers. page	5
The electrical connections page	6
Door reversal directions. page	7
Your appliance page	8
Operation page	9
Freezer Controls page	9
Temperature control page	9
Freezing fresh food page	9
Frozen food storage page	10
Thawing page	10
Ice making page	10
Health and safety guidelines page	11
Defrosting page	12
Maintenance and cleaning page	13
What happens if something goes wrong? page	14
Guarantee conditions page	15

TECHNICAL SPECIFICATIONS

DIMENSIONS

Height	124 cm
Width	54 cm
Depth	57 cm

POWER SUPPLY VOLTAGE AND FREQUENCY	220-240 V / 50 Hz
------------------------------------	-------------------

TOTAL POWER ABSORBED	130 W
----------------------	-------

AVERAGE DAILY UNITS ELECTRICITY*	1.25 kWh
----------------------------------	----------

GROSS CAPACITY	186 l
----------------	-------

NET CAPACITY	150 l
--------------	-------

STAR RATING	
-------------	---

* This figure is based on standard test results in accordance with European Standard EN153. Actual consumption will depend on how the appliance is used and where it is located.

WARNINGS

IT IS MOST IMPORTANT THAT THIS INSTRUCTION BOOK SHOULD BE RETAINED WITH THE APPLIANCE FOR FUTURE REFERENCE. SHOULD THE APPLIANCE BE SOLD OR TRANSFERRED TO ANOTHER OWNER, OR SHOULD YOU MOVE HOUSE AND LEAVE THE APPLIANCE, ALWAYS ENSURE THAT THE BOOK IS SUPPLIED WITH THE APPLIANCE IN ORDER THAT THE NEW OWNER CAN GET TO KNOW THE FUNCTIONING OF THE APPLIANCE AND THE RELEVANT WARNINGS.

THESE WARNINGS ARE PROVIDED IN THE INTEREST OF SAFETY. YOU MUST READ THEM CAREFULLY BEFORE INSTALLING OR USING THE APPLIANCE.

- “ This appliance is designed to be operated by adults. Children should not be allowed to tamper with the controls or play with the product.
- “ Any electrical work required to install this appliance should be carried out by a qualified electrician or competent person.
- “ This product should be serviced by an authorised ZANUSSI Service Centre, and only genuine spare parts should be used.
- “ It is dangerous to alter the specifications or modify this product in any way.
- “ Care must be taken to ensure that the appliance does not stand on the electrical supply cable.
- “ ZANUSSI domestic refrigerators, freezers and fridge/freezers are designed to be used specifically for the storage of edible foodstuffs only.
- “ There are working parts in this product which heat up. Always ensure that there is adequate ventilation as a failure to do this will result in possible food loss. See installation instructions.
- “ Parts which heat up should not be exposed. Wherever possible, the back of the appliance should be close to a wall but leaving the required distance for ventilation as stated in the installation instructions.
- “ Before defrosting, cleaning or maintenance work is carried out, be sure to switch off the appliance and unplug it.
- “ Frozen food must NOT be re-frozen once it has thawed out.
- “ Do not place carbonated or fizzy drinks in the freezer as it creates pressure on the container, which may cause it to explode, resulting in damage to the appliance.
- “ The cooling plate or refrigerated freezer shelves in this appliance contain channels through which the refrigerant passes. If these are punctured this would cause substantial damage to the appliance and result in food loss. DO NOT USE SHARP INSTRUMENTS to scrape off frost or ice. Under NO circumstances should solid ice be forced off the lining or shelves. Solid ice should be allowed to thaw, when defrosting the appliance. See Defrost instructions.
- “ The appliance should be left for 2 hours after installation before it is turned on in order to allow the refrigerant to settle.
- “ This appliance is heavy. Care should be taken when moving it.
- “ Do not remove items from the freezer if your hands are damp/wet, as this could cause skin abrasions or “frost/freezer burns”.
- “ Ice lollies can cause “frost/freezer burns” if consumed straight from the freezer.
- “ Manufacturers’ storage recommendations should be strictly adhered to. Refer to relevant instructions.
- “ Under no circumstances should you attempt to repair the appliance yourself. Repairs carried out by inexperienced persons may cause injury or serious malfunctioning. Refer to your local ZANUSSI Service Centre and always insist on genuine spare parts.

CONSERVATION

In the interests of the Environment:

When disposing of your old fridge, freezer or fridge/freezer.

Help to keep your country tidy – use authorised disposal sites for your old appliances.

For maximum efficiency:

Make sure that the appliance is cleaned properly.

Make sure that the door is closed properly.

Do not position the appliance near to sources of heat.

Do not over-fill your appliance, air **MUST** be allowed to circulate.

INSTALLATION

Warning

IF YOU ARE DISCARDING AN OLD APPLIANCE THAT HAS A LOCK OR CATCH ON THE DOOR, PLEASE ENSURE THAT IT IS MADE UNUSABLE TO PREVENT YOUNG CHILDREN BEING TRAPPED INSIDE.

Depending upon the position which you choose for your appliance, you may wish to reverse the way in which the door opens. To do this, refer to instructions on “Door reversal directions” paragraph.

Positioning

This appliance is designed to operate in ambient temperatures between 10°C (50°F) and 32°C (90°F). It should be located in a dry atmosphere, out of direct sunlight and away from extreme temperature e.g. not next to a cooker or other sources of direct heat, or in a very cold room e.g. an outhouse, where the temperatures may fall below 10°C (50°F). If these temperatures are exceeded i.e. colder or warmer, then the appliance may not operate correctly.

You should also ensure that air can circulate freely around the back and the top of the cabinet. There must also be at least 100 mm (4”) distance between the top of the cabinet and any overhanging kitchen furniture (Fig. 1-A). Ideally, the appliance should not be positioned beneath overhanging furniture (Fig. 1-B).

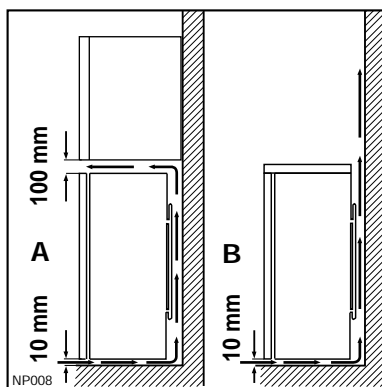

Fig 1

There should also be a gap of 25 mm either side of the appliance. Do not obstruct the space underneath. The back of the cabinet may be placed close to the wall but must not touch it. DO NOT install in places with restricted ventilation.

Adjust the level of the appliance by screwing out the adjustable foot, or feet, at the bottom of the cabinet using your fingers or a spanner (see Fig. 2).

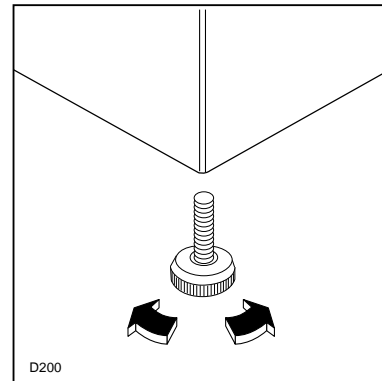

Fig 2

Rear spacers

The plastic bag containing all relevant documentation also contains two rear wall spacers to be fitted into special slots on the back of the appliance. Fit the spacers into the slots, taking care to ensure that the arrow (A) is positioned as shown in Figure 3.

Next, turn them through 45° (arrow in vertical position) until they lock into place.

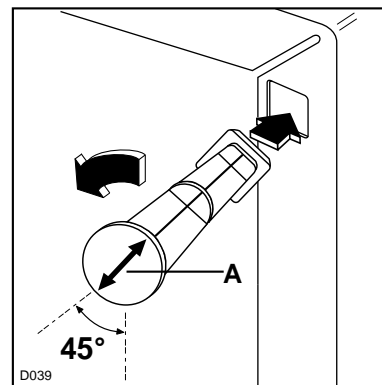

Fig 3

The electrical connections

WARNING: THIS APPLIANCE MUST BE EARTHED.

The manufacturer declines any liability should this safety measure not be observed.

If the plug that is fitted to your appliance is not suitable for your socket outlet, it must be cut off and the appropriate plug fitted.

Remove the fuse from the cut off plug.

The cut off plug should then be disposed of to prevent the hazard of shocks in case it should be plugged into a 13amp socket in another part of your home.

Important

The wires in the mains lead are coloured in accordance with the following code:

Green and Yellow	- Earth
Blue	- Neutral
Brown	- Live

If you fit your own plug, the colours of the wires in the mains lead of your appliance may not correspond with the markings identifying the terminals in your plug, proceed as follows:

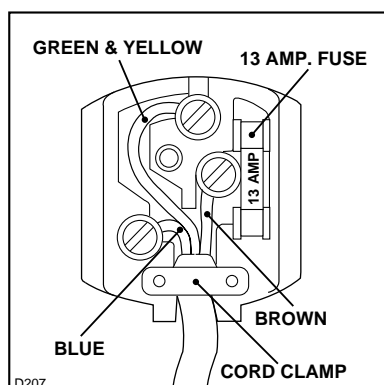

Fig 4

Connect the Green and Yellow (earth) wire to the terminal in the plug which is marked with the letter «E» or the earth symbol \oplus , or coloured green and yellow.

Connect the blue (neutral) wire to the terminal in the plug which is marked with the letter «N» or coloured black.

Connect the brown (live) wire to the terminal in the plug which is marked with the letter «L» or coloured red.

The plug moulded onto the lead incorporates a fuse. For replacement, use a 13amp BSI362 fuse. Only ASTA or BSI approved fuses should be used.

The plug must not be used if the fuse cover/carrier is lost. The cover/carrier is indicated by the coloured insert at the base of the plug.

A replacement cover/carrier must be obtained from your local Zanussi Service Force Centre whose address is listed in the Customer Care Booklet which accompanies your instruction manual.

This appliance complies with the E.E.C. Directive No. 87/308 of 2.6.87 relative to radio interference suppression.

CE This appliance complies with the following E.E.C. Directives:

- **73/23 EEC** of 19.2.73 (Low Voltage Directive) and subsequent modifications;
- **89/336 EEC** of 3.5.89 (Electromagnetic Compatibility Directive) and subsequent modifications.

Please ensure that when the appliance is installed it is easily accessible for the engineer in the event of a breakdown.

Before using

Remove all securing tapes. Wash inside the appliance with lukewarm water and a little bicarbonate of soda (one teaspoonful to one quart of water). Do not use soap or detergent as the smell might linger. Dry thoroughly.

Door reversal directions (Fig. 5)

Before carrying out the operations described below, pull out the mains plug from the wall socket.

To carry out this reversal go through the following steps:

dismantle the lower hinge (3), pin (1), the threaded insert (4) and the screw (2);

slide the door out from pin (5), unscrew the pin and reposition on the opposite side;

unscrew the left front foot and reposition on the opposite side;

unscrew the two screws which mask the holes for fixing the hinge from the left front side;

reassemble the door;

reassemble the lower hinge (turning it 180°), the threaded insert, the pin and the screw on the opposite side, as shown in the figure;

dismantle the handle (6) and reassemble it on the opposite side.

Attention

After completion of the door reversibility operation, verify that the door gasket is adherent to the cabinet.

If the ambient temperature is cold (i.e. in Winter), the gasket may not fit perfectly to the cabinet. In that case, wait for the natural fitting of the gasket or accelerate this process by heating up the part involved with a normal hairdrier.

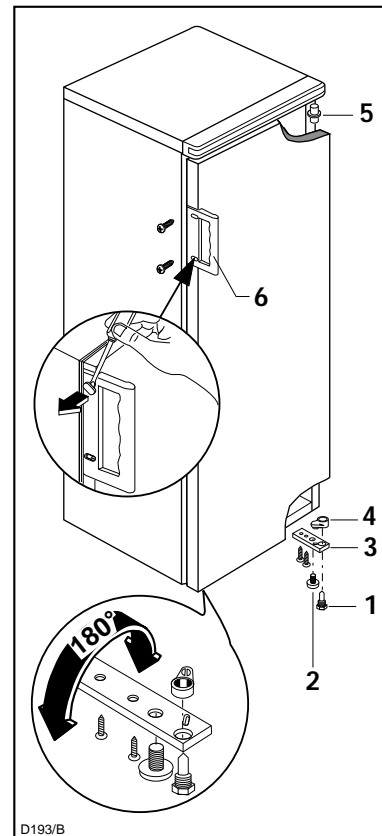
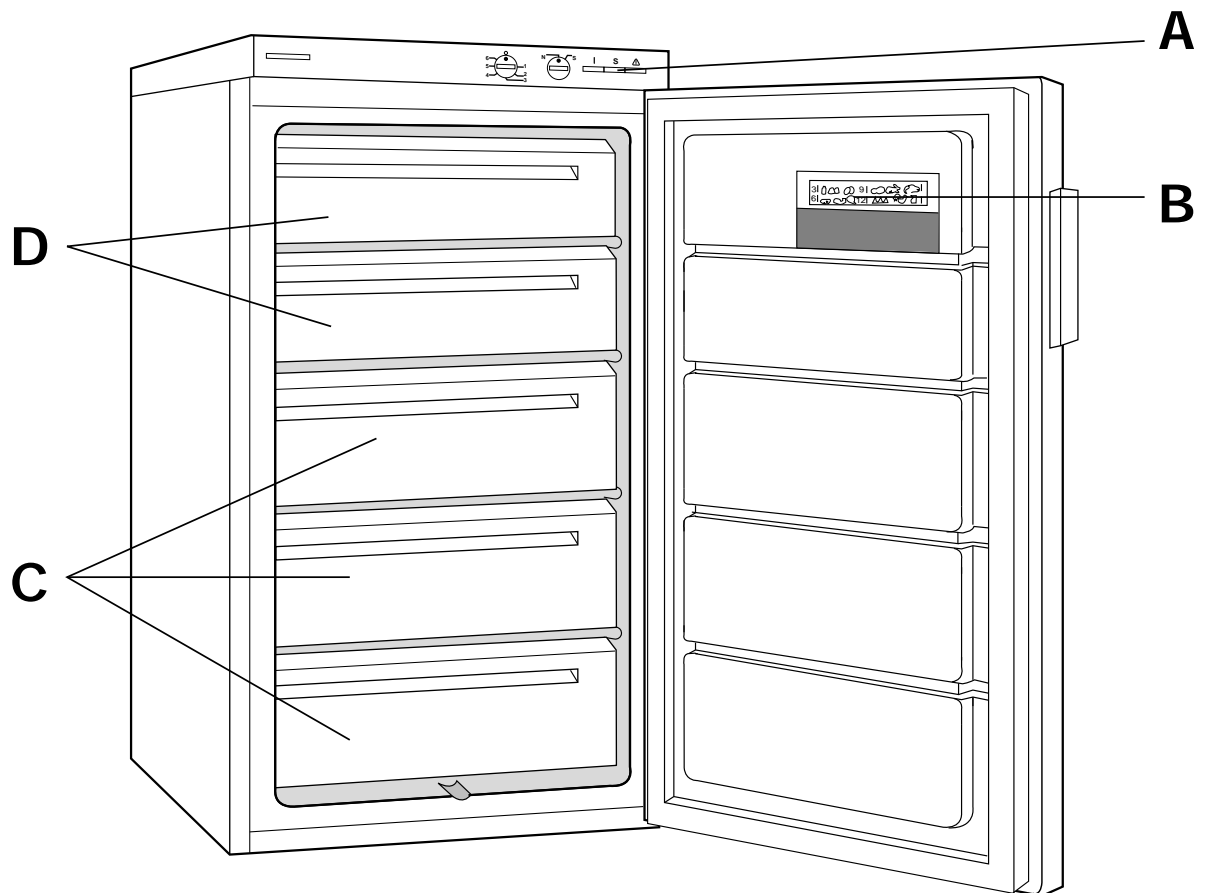

Fig. 5

YOUR APPLIANCE



A - Freezer controls

B - Freezer calendar (recommended storage times for frozen foods) and produce storage card (write on/wipe off card for recording what has been stored in the freezer and when)

C - Frozen food storage

D - Freezing fresh foods

OPERATION

Freezer Controls (Fig. 6)

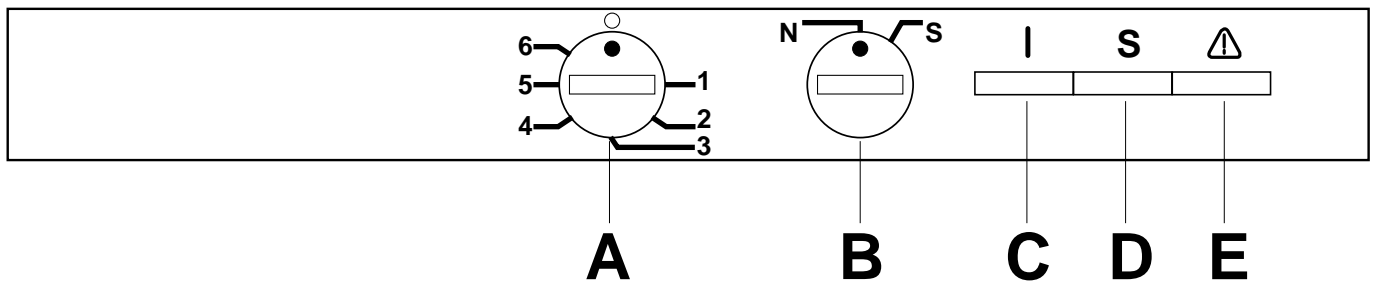

Fig. 6

- A** - Thermostat control
- B** - Fast freeze switch
- C** - Mains-on light (green)
- D** - Fast freeze light (yellow)
- E** - Warning light (red)

Start your appliance

Insert the plug into the wall socket. The pilot light (C-Fig. 6) will light up to show that the appliance is on.

Temperature control

The temperature within the freezer is controlled by the thermostat situated at the top of the cabinet (A-Fig. 6).

To operate the freezer proceed as follows:

Turn the thermostat control beyond the «O» position.

When you first start the freezer, we suggest that you turn the thermostat control to a medium setting, between 2 and 4. For easier turning of this control, use a small coin. The internal temperature of the freezer is automatically adjusted by the thermostat to ensure safe food storage. However, if the appliance is working in unfavourable room conditions such as poor ventilation, high temperature and frequent door openings, it may be necessary to select a more suitable setting.

To obtain a lower temperature, turn the thermostat control to the higher numbers; to obtain a higher temperature turn the control to the lower numbers.

Warning light (red)

If the temperature warning light (E) lights up, it indicates that the temperature within the freezer has reached a level where the safe food storage is no longer ensured.

When the freezer is first switched on, the warning light will stay on until the temperature has dropped to a safe level for the storage of frozen food.

Freezing fresh food

In any 24 hour period you can freeze up to 18 kg of fresh food.

When you first start the freezer or after a period of non-use, turn the knob (B-Fig. 6) to «S» (fast freeze position) 2-3 hours before you want to freeze your food (the yellow light (D) lights up).

If the freezer is already in operation, the fast-freeze switch should be activated about 24 hours before freezing fresh food. This time can be shortened, depending on the quantity of food to be frozen. After the time has elapsed place the food to be frozen in the top compartments of the freezer as these are the coldest parts (9 kg in each compartment).

Once the food is completely frozen (which could take up to 24 hours) return the fast freeze switch to the «N» position; the yellow light (D) goes off.

Distribute the frozen food packages in the other compartments, so that the top compartments can be used for a further freezing operation.

Only freeze top quality, fresh and thoroughly cleaned foodstuffs.

Do not allow fresh food to touch food which is already frozen.

During the freezing process, ensure that the freezer door remains closed.

Frozen food storage

When you first start the freezer or if the freezer has been out of use for some time, we advise you to run your appliance for at least two hours in the «fast freeze» mode before storing frozen food.

To obtain the best performance from this appliance, we strongly recommend that you make sure that the commercially frozen foodstuffs were adequately stored by the retailer and, furthermore, be sure that these frozen foodstuffs are transferred from the foodstore to the consumer in the shortest possible time (a temperature increase of the frozen food could shorten its storage period).

It is also advisable not to exceed the storage period indicated by the producer of the food.

Finally, do not open the door frequently or leave it open longer than is absolutely necessary.

Attention

Do not put carbonated liquids, (fizzy drinks etc.), in the freezer compartment.

Water ices, if consumed immediately after removal from the freezer, can possibly result in a low temperature skin burn.

Do not remove items from the freezer if your hands are damp/wet, as this could cause skin abrasions or “frost/freezer burns”.

If there is a power failure during the storage of frozen food, do not open the door during the whole time of the power failure. If the freezer is fully loaded, the frozen food will not be affected if the power cut is of short duration; otherwise, it is recommended to consume the food within a very short time.

Thawing

Deep frozen or frozen food, prior to being used, can be thawed in the fridge or at room temperature depending on the time available. Small food items may even be cooked from frozen; in this case cooking will take longer.

Any frozen food which is allowed to thaw accidentally should either be eaten as soon as possible or thrown away. Alternatively, if the food is uncooked and has not been completely defrosted it can be cooked and then refrozen.

Defrosted cooked food must never be refrozen.

Ice making

Fill the ice trays with water to the top of each ice cube compartment, and place them in the freezer compartment. To release the ice cubes, twist the tray along its length.

Never use a sharp instrument to remove ice trays.

HEALTH AND SAFETY GUIDELINES

Because of consumer demand, preservatives have been removed from many pre-prepared foods. This together with the changes in shopping habits to a once-a-week shop, mean that safe handling and storage of food is even more important than ever.

The following tips should help you to ensure that the food in your home is in as perfect condition as possible.

- “ Keep the time between buying chilled food and placing it in your freezer as short as possible. Tests showed that the temperature of 1 litre of orange juice rose to 22°C in an hour between the supermarket and home. It then took 11 hours to get down to 7°C in the refrigerator.
- “ Keep the freezer door closed as much as possible. Remember that warm air is flowing in as you are deciding what to have for tea!
- “ Do not push food together too much, try to allow air circulate around each item.
- “ Cool cooked food as quickly as possible but do NOT place in the freezer until cool. (Leave food in a place as cool as possible in order that it can then be placed in the freezer as soon as possible).
- “ Do not store food uncovered.
- “ The best way to defrost food is to put it in the refrigerator to thaw slowly.
- “ Ensure that food placed in the freezer is dated and labelled and used in date order to ensure that food is consumed at its best.
- “ It is important that food is used before its “best before” date.
- “ Always wash your hands with soapy water and dry them with a clean towel before handling food.
- “ Keep work surfaces clean and avoid cross contamination by not using the same work surface or knife, without washing them thoroughly in between.
- “ Use kitchen roll wherever possible for cleaning up food. If you use a dishcloth, be sure to boil it frequently.

Defrosting

The freezer compartment will become progressively covered with frost. This should be removed with the special plastic scraper provided, whenever the thickness of the frost exceeds 1/4". During this operation it is not necessary to switch off the power supply or to remove the foodstuffs. However, when the ice becomes very thick on the inner liner, complete defrosting should be carried out and it is advisable to carry out this operation when the appliance is empty.

To carry out complete defrosting proceed as follows:

Remove any stored food, wrap it in several layers of newspaper and put it in a cool place.

Turn the thermostat control (A-Fig. 6) to the «O» setting.

Leave the door open.

Introduce the plastic scraper in the appropriate seating as shown in Figure 7 and place underneath a basin to collect the defrost water.

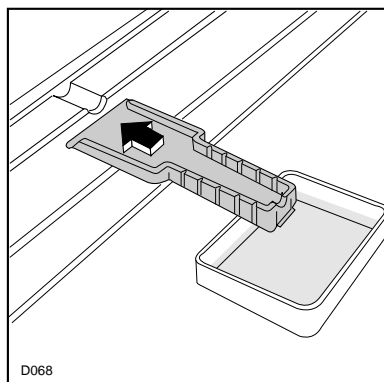

Fig. 7

When defrosting is completed, dry the interior thoroughly.

Turn the thermostat control to a medium setting between 2 and 4 and, after letting the appliance run for at least two hours in the «fast freeze» mode, replace the previously removed food into the compartment.

Important

A temperature rise of the frozen food packs, during defrosting, may shorten their safe storage life.

Never use sharp metal tools to scrape off frost from the evaporator as this could damage the appliance beyond repair.

Attention!

«In the event of a power failure causing the temperature within your freezer to rise, do not re-freeze the food without checking its condition. The following guidelines should assist you.»

Ice-cream: once thawed should be discarded.

Fruits & Vegetables: if soft should be cooked and used up.

Breads & Cakes: can be re-frozen without danger.

Shellfish: should be refrigerated and used up quickly.

Cooked Dishes: i.e. casseroles should be refrigerated and used up.

Large Pieces of Meat: can be re-frozen providing there are still ice crystals remaining within them.

Small Joints: should be cooked and can then be re-frozen as cooked dishes.

Chicken: should also be cooked and re-frozen as a cooked dish.

MAINTENANCE AND CLEANING

Before any maintenance or cleaning work is carried out, DISCONNECT the appliance from the ELECTRICITY supply.

Internal cleaning

Clean the inside and accessories with warm water and bicarbonate of soda (5ml to 0.5 litre of water). Rinse and dry thoroughly.

NEVER USE DETERGENTS, ABRASIVE POWDERS, HIGHLY PERFUMED CLEANING PRODUCTS OR WAX POLISHES, TO CLEAN THE INTERIOR AS THESE WILL DAMAGE THE SURFACE AND LEAVE A STRONG SMELL.

External cleaning

Wash the outer cabinet with warm soapy water. Do NOT use abrasive products.

Once or twice a year dust the condenser (black grill) and the compressor at the back of the appliance, with a brush or vacuum cleaner.

You MUST ensure that the appliance is switched OFF. An accumulation of dust will affect the performance of the appliance and cause excessive electricity consumption.

When the appliance is not in use

When the appliance is not in use for long periods, disconnect from the electricity supply, empty all foods and clean the appliance, leaving the door ajar to prevent unpleasant smells.

WHAT HAPPENS IF SOMETHING GOES WRONG?

Before contacting your local Zanussi Service Force Centre, check the following points:

The appliance does not work...

Check that:

- “ There is power at the socket.
- “ Ensure that there is not a power cut by checking the household lights.
- “ The fuse has not blown.
- “ The air circulation passages are not covered.

Vibration or abnormal noises...

- “ You may hear faint gurgling or bubbling sounds when the refrigerant is pumped through the coils of tubing at the rear, to the cooling plate/ evaporator or to the fixed freezer shelves. When the compressor is on, the refrigerant is being pumped round, and you will hear a whirring or pulsating noise from the compressor. A thermostat controls the compressor, and you will hear a faint “click” when the thermostat cuts in and out.

Other points to check...

Check that:

- “ Have you turned the thermostat to the correct setting?
- “ Has door been left open causing the temperature to rise?
- “ Sometimes the freezer door will be difficult to open shortly after you have closed it. Don't worry this is due to pressure difference which will quickly equalise and allow the door to open normally.

If, after the above checks, there is still a fault, call your local Zanussi Service Force Centre, whose address can be found in the accompanying Customer Care Booklet, and can also be found in your local telephone directory under «Z».

In-guarantee customers should ensure that the above checks have been made as the engineer will make a charge if the fault is not a mechanical or electrical breakdown.

Please note that proof of purchase is required for any in-guarantee service calls.

Before contacting your local Zanussi Service Centre, make a note of the model and serial number. This information can be found on the rating plate situated inside the cabinet behind the bottom fridge/freezer drawer.

SERVICE DETAILS - ADHESIVE LABEL

When you return your guarantee card to Zanussi Ltd., you will receive an Appliance Guarantee and Maintenance Record Card together with an adhesive label. The label can be stuck to the machine or adjacent furniture.

PEACE OF MIND FOR TWELVE MONTHS

Zanussi standard guarantee conditions

This guarantee is in addition to your statutory and other legal rights which will not be excluded or in any way diminished by the return of this guarantee card.

We, Zanussi Ltd., undertake that if, within twelve months of the date of the purchase, this ZANUSSI appliance or any part thereof is proved to be defective by reason only of faulty workmanship or materials, we will, at our option, repair or replace the same **FREE OF ANY CHARGE** for labour, materials or carriage on condition that:

- “ The appliance has been correctly installed and used only on the electricity supply stated on the rating plate.
- “ The appliance has been used for normal domestic purposes only, and in accordance with the manufacturer's operating and maintenance instructions.
- “ The appliance has not been serviced, maintained, repaired, taken apart or tampered with by any person not authorised by us.

All service work under this guarantee must be undertaken by a Zanussi Service Centre.

Home visits are made between **8.30am** and **5.30pm** Monday to Friday. Visits may be available outside these hours in which case a **premium** will be charged.

Any appliance or defective part replaced shall become our property.

Exclusions

This guarantee does not cover:

- “ Damage or calls resulting from transportation, improper use or neglect, the replacement of any light bulbs or removable parts of glass or plastic.
- “ Costs incurred for calls to put right machines improperly installed or calls to machines outside the United Kingdom.
- “ Appliances found to be in use within a commercial environment, plus those which are the subject of rental agreements.
- “ Products of Zanussi manufacture which are NOT marketed by Zanussi Ltd.
- “ EU Countries - The standard guarantee is applicable but is subject to the owner's responsibility and cost to ensure the appliance meets the standards set by the country to which the product is taken. The Zanussi Company in the country concerned will be pleased to advise further. Sight of your purchase receipt will be required by them.

